

Installation Instructions
Ultra-Shift Light™ with 4 Point Technology

PRECAUTIONS:

- ❑ Read ALL instructions before installing instrument.
- ❑ Follow ALL safety precautions when working on vehicle-wear safety glasses!
- ❑ ALWAYS disconnect (-) negative battery cable before making electrical connections.

HELP?:

- ❑ If after reading these instructions you don't fully understand how to install your instrument(s), contact your local Stewart Warner distributor, or contact our Technical Support Team toll free at **1 866-797-7223 (SWP-RACE)**.
- ❑ Additional applications information may be found at www.SW-Performance.com.

GENERAL APPLICATION:

- ❑ Designed for Drag Racing applications using transmissions requiring 1 through 4 gear changes during a race
- ❑ 12-volt DC negative (-) ground electrical systems (11-20 VDC operating voltage range).
- ❑ The upper rpm limit of the shift light is variable, and depends upon the PPR setting. The upper RPM limit for the PPR settings are .5-2 PPR= 18,000 RPM, 2.5-4 PPR= 15,000 RPM, and 5-6 PPR= 13,000 RPM.

1

Figure 1

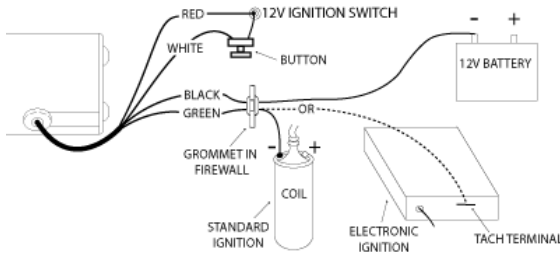

NEVER CONNECT GREEN WIRE TO THE COIL WHEN USING AN MSD OR SIMILAR HIGH OUTPUT CAPACITIVE DISCHARGE STYLE IGNITION SYSTEM

Damage to the shift light will occur—Connect GREEN wire to the tachometer terminal only.

3

CONFIGURATION MENU, OPTIONS, & DESCRIPTIONS:

The Configuration Menu sets up the different options and calibrations to establish the general overall operation of the Ultra-Shift Light™, and should be set up first.

- ❑ **dISP** - Display options (**ERCh**, **9ERr**, **0FF**). This determines the information shown on the display.
 - **ERCh** - Current engine RPM is shown on the display.
 - **9ERr** - Current gear is shown on the display.
 - **0FF** - Nothing displayed. Recall information can still be viewed.
- ❑ **SPt5** - Number of gear shifts during a race (1, 2, 3, 4). Example: A 4-speed transmission has 3 gear changes.
- ❑ **5t** - Staging option (**0n**, **0FF**). When the staging option is set to **0n** and the white wire has +12 volts applied (indicating that the vehicle is staged), the Ultra-Shift Light™, will remain off if the RPM's remain within programmed window, flash when over the high RPM setting, or remain on when under the low RPM setting.
- ❑ **PPr** - Pulses/revolution of signal (5, 1, 1.5, 2, 2.5, 3, 4, 5, 6).

TIP: When connecting to an engine with a distributor, generally, the old rule, half the number of cylinders = PPR, still applies. When connecting to the signal wire to a coil pack that drives 2 cylinders, generally, the PPR = 1. When connecting to a "coil on plug" ignition or one coil for each cylinder, the best option is to look for a tach signal coming out of the ECU, but the .5 PPR setting may work when directly connected to any one of the coils. If this connection is erratic or does not function correctly, a tachometer adapter may be required. Call technical support or visit www.SW-Performance.com for more information.

NOTE: An improper PPR setting will cause the RPM display and shift light to be inaccurate.

5

SHIFT-LIGHT MOUNTING:

- ❑ The *Ultra-Shift Light™* may be mounted on a roll cage, steering column, dash, existing tachometer, or other high visibility locations.
- ❑ To mount the *Ultra-Shift Light™* on the dash, use the bracket and screws provided.
- ❑ To mount to a roll bar or steering column, use a hose clamp to secure.
- ❑ To mount on an existing tachometer, loosen the mounting strap and insert the base of the *Ultra-Shift Light™* under strap and retighten the bolts.

SHIFT-LIGHT WIRING (FIGURE 1):

1. Disconnect negative (-) battery cable.
2. Using 18-ga. wire, connect the (**BLACK**) wire to a clean (rust/paint-free) ground, preferably battery negative terminal.
3. Using 18-ga. wire, connect the (**RED**) wire to a switched +12V source, like the ignition wire.
4. Using 18-ga. wire, connect the (**GREEN**) wire to the coil negative or the tachometer terminal of the ignition module (Refer to the Configuration Menu Descriptions section for connection options).
5. Using 18-ga. wire, connect the (**WHITE**) wire to one terminal of a momentary contact button switch and connect the other terminal to a +12V source.

NOTE: The (**WHITE**) wire **MUST** be energized by a +12 volt signal during staging and then de-energized at the start of the race for proper operation. This signal is required by the Ultra-Shift Light™ to indicate when the vehicle is staged and when the race begins, even if the staging option is not used. A momentary button switch may be used, or you may tap into your trans. brake, or other similar circuits.

6. Reconnect the negative (-) battery.

2

ULTRA-SHIFT W/4-POINT TECHNOLOGY OPERATION:

- ❑ Once the vehicle is on the starting line, or staged, press and hold the button to activate the white wire. This will put the unit into the **Staging Mode** if **5t** is set to **0n** in the Configuration Menu, and clear the memory in preparation for new data from the pending race. **Staging Mode** is used to aid the driver in keeping the RPM within the correct launch range without watching the tachometer, to attain a competitive launch. If the RPM is in the user programmable range, the light will be out. If the RPM is low, outside of the user programmable range, the light will come on solid. If the RPM is high, outside of the user programmable range, the light will flash. If the **Staging Mode** is set to **0FF**, the unit will function normally when staged.
- ❑ Release the button at the start of the race. This does two things, **Staging Mode** is exited and **Race Mode** is started. Once in **Race Mode**, the time delay starts to prevent any wheel spin or drastic RPM changes to trigger a false shift.
- ❑ While in **Race Mode**, the unit will automatically analyze the engine RPM to pick out shifts and increment to the next shift point. Even if the vehicle is shifted before the light comes on, or short shifted, the unit will recognize the shift and move to the next shift point.
- ❑ The unit will stay in **Race Mode** until the end of the race, or until the engine PRM drops below 2000 RPM for 2 seconds.
- ❑ During **Race Mode**, the unit will record a peak RPM for each gear and a driver reaction time for each shift. After the last shift, the unit will record a peak RPM, which should be the RPM at the finish line, or trap RPM. This information is stored until it is cleared by the user, or the white wire is energized to indicate the start of another race (to view the information refer to the MEMORY FUNCTIONS section).
- ❑ When the unit is not in **Racing Mode**, for example driving to and from the racetrack, the light will activate at the programmed RPM for the first shift and no data is stored.

4

SETUP MENU, OPTIONS, & DESCRIPTIONS:

The Setup Menu sets the actual values for the different options activated in the Configuration Menu. This menu is a "LIVE" menu, meaning that the available options are linked to the configuration menu. For example, if there are only 2 shift points activated in the configuration menu, **SP 1** and **SP 2** will be the only available shift points in this menu.

- ❑ **SP 1** - Shift RPM for the first shift point.
- ❑ **SP 2** - Shift RPM for the second shift point.
- ❑ **SP 3** - Shift RPM for the third shift point.
- ❑ **SP 4** - Shift RPM for the fourth shift point.
- ❑ **dELy** - This option sets a delay value from 0.1 to 1 second. This delay determines how long the Ultra-Shift Light™ waits, after the start of the race, to recognize the first shift. This delay prevents wheel spin, or dramatic RPM changes at launch, from triggering false shifts. A good starting point value should be about half the length of time from launch to the first shift.

NOTE: The following options are only available if the **5t** - Staging option is set to **0n** in the configuration menu.

- ❑ **5tL** - Stage low RPM. When the Ultra-Shift Light™ staging option is enabled, this is the low value for the staging RPM window.
- ❑ **5tH** - Stage high RPM. When the Ultra-Shift Light™ staging option is enabled, this is the high value for the staging RPM window.

NOTE: The upper rpm limit of the shift light is variable, and depends upon the PPR setting. The upper RPM limit for the PPR settings are .5-2 PPR= 18,000 RPM, 2.5-4 PPR= 15,000 RPM, and 5-6 PPR= 13,000 RPM.

6

PROGRAMMING THE CONFIGURATION MENU (FIGURE 2):

Programming is done through the two buttons, **SCROLL & SELECT**, on the back of the unit. While in programming mode, the **SCROLL** button scrolls through the menus and the **SELECT** button selects the menu options. All settings are maintained when there is no power to the unit.

1. To enter the Configuration Menu, with the power off, press and hold both **SCROLL & SELECT** buttons simultaneously, and apply power to the unit.
2. Release both buttons.
3. *d 15P* will appear on the display.
4. Press the **SELECT** button to select the display option, then press the **SCROLL** button to scroll to the desired option (*tRch, 9ERr, 0FF*). Press the **SELECT** button to set the desired option and return to the Configuration Menu.
5. Press the **SCROLL** button to scroll to *5P1*.
6. Press the **SELECT** button to select the number of shift points, then press the **SCROLL** button to scroll to the desired number of shift points (*1 2 3 4*). Press the **SELECT** button to set the desired number and return to the Configuration Menu.
7. Press the **SCROLL** button to scroll to *5t*.
8. Press the **SELECT** button to select the staging option, then press the **SCROLL** button to set *On* or *OFF*. Press the **SELECT** button to set the desired value and return to the Configuration Menu.
9. Press the **SCROLL** button to scroll to *PPr*.
10. Press the **SELECT** button to select the PPR, then press the **SCROLL** button to scroll to the proper PPR setting. Press the **SELECT** button to set the desired setting and return to the Configuration Menu.
11. The Ultra-Shift Light™ will automatically exit programming mode and save all changes 10 seconds after the last button press.

7

Figure 2

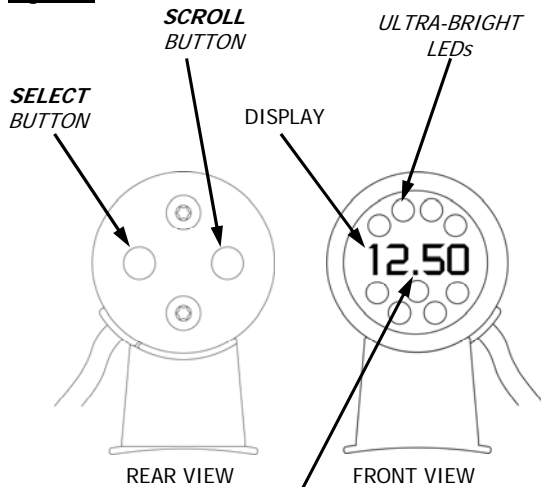

In order to display up to 18,000 RPM with only 4 digits, a decimal point is displayed and the right most digit is dropped when the RPM exceeds 9990.

9

LED CLUSTER INTENSITY (4 LEVELS):

There are four selectable intensity, or brightness settings for the LED cluster. These are used to adjust to the changing racing conditions for the best visibility (nighttime, overcast, and bright daytime racing).

1. To change the intensity of the LED cluster, press and hold **SCROLL** button to enter *intensity select mode*.
2. The LED cluster will turn on at the highest intensity for one second, change to the medium-high intensity for one second, change to the medium-low intensity for one second, then to the lowest intensity for one second, then repeat.
3. To select the desired intensity, simply release **SCROLL** button when the LED cluster is at the desired intensity. The LED cluster will flash once at the newly selected intensity to confirm the setting.

11

PROGRAMMING THE SETUP MENU (FIGURE 2):

1. To enter the Setup Menu, apply power, momentarily press both **SCROLL & SELECT** buttons, and then release both buttons.

2. *5P 1* will appear on the display.
3. Press the **SELECT** button to select the first shift point RPM. Press the **SCROLL** button to scroll to the desired RPM. Each time the **SCROLL** button is pressed and released, the value will increase by 10 RPM. Pressing and holding the **SCROLL** button will cause the RPM value to increase rapidly. Press the **SELECT** button to set the desired RPM and return to the Setup Menu.
4. Press the **SCROLL** button to scroll to *5P 2*. Repeat step 3 for the second shift point RPM. Repeat for all available shift points.
5. Press the **SCROLL** button to scroll to *dELAY*.
6. Press the **SELECT** button to select the delay time, and then press the **SCROLL** button to set the delay time (0.1 to 1 second). Press the **SELECT** button to set the desired time and return to the Setup Menu.
7. Press the **SCROLL** button to scroll to *5tL*.
8. Press the **SELECT** button to select the staging-low RPM value, then press the **SCROLL** button to scroll to the proper RPM value. Press the **SELECT** button to set the desired value and return to the Setup Menu.
9. Press the **SCROLL** button to scroll to *5tH*.
10. Press the **SELECT** button to select the staging-high RPM value, then press the **SCROLL** button to scroll to the proper RPM value. Press the **SELECT** button to set the desired value and return to the Setup Menu.
11. The Ultra-Shift Light™ will automatically exit programming mode and save all changes 10 seconds after the last button press.

8

MEMORY FUNCTIONS (Data Recall and Clear)(FIGURE 2):

The Ultra-Shift Light With 4-Point Technology™ stores a peak RPM value for each shift, as well as one peak RPM after the last shift, which should be the "trap" RPM at the end of the race. In addition to the peak RPM values, a driver reaction time is recorded for each shift.

To recall the data after a run, momentarily press the **SELECT** button.

1. *P 1* will be displayed followed by the peak RPM value for 1st gear, after a short delay, *t 1* will be displayed, followed by the driver reaction time in milliseconds. After a short delay, the display will repeat the information.
2. Press the **SELECT** button to get the 2nd gear peak RPM, *P2* and the driver reaction time for the second shift, *t2*.
3. Press the **SELECT** button again to the 3rd shift information, *P3* and *t3*, and again for the 4th shift information, *P4* and *t4*.
4. Press the **SELECT** button again to display the *t-RP* RPM value.
5. Pressing the **SELECT** button again will go back to the *P 1* and *t 1* information and the menu will repeat.
6. The Ultra-Shift Light™ will automatically exit the recall mode 10 seconds after the last button press.
7. To clear all of the stored RPM and reaction time values, press and hold the **SELECT** button for at least 3 seconds. The LED cluster will flash indicating a successful clear, then return to normal operation.

NOTE: Anytime the white wire is activated, all stored values are cleared in preparation for a new race. If the previous information has not been retrieved, it will be lost.

TIP: After evaluating the peak RPM values from a couple of runs, the information may be valuable for adjusting the shift point RPM values to fine tune the setup. Example 1: If the peak RPM value for the first shift RPM recall is usually 220 RPM over the optimal shift point, that shift point RPM may need to be lowered by 220 RPM to adjust for the driver's reaction time. Example 2: Perhaps the second gear shift RPM recall is usually 100 RPM under the optimal shift point, that shift point RPM may need to be raised by 100 RPM.

10

CLEANING DIRECTIONS:

- For proper cleaning of instrumentation/accessories, use a glass cleaner or mild detergent with a spray on and wipe method.

WARRANTY INFORMATION:

TWO (2) YEAR LIMITED WARRANTY. SWP products are warranted against defects in workmanship and materials for a period of two (2) years from the date of purchase. Proof-of-purchase is required; otherwise, the warranty period shall default to two (2) years from date-of-manufacture (as indicated by the date code on the product). See detailed Warranty Policy for other Terms & Conditions.

STEWART WARNER PERFORMANCE

1-866-SWP-RACE (797-7223)

www.SW-Performance.com



12